

24 VAC SYSTEM CONTROL KIT

Model: CK-43

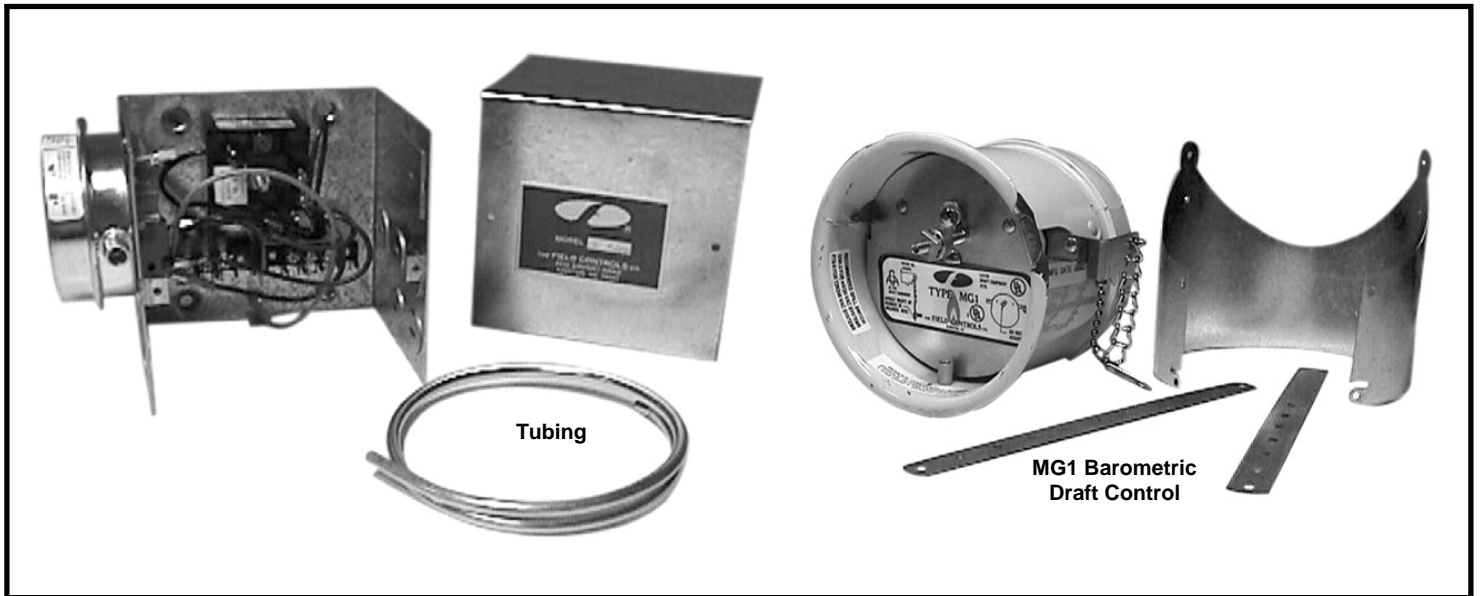

The CK-43 is designed for use with the SWG Series Power Venter for controlling Natural Gas and L.P. Gas Draft Induced appliances.

Control kits control the operation of SWG Power Venters. Control Kits can also control the operation of Field Draft Inducers and Combustion Air Systems.

ITEMS INCLUDED IN KIT

- 1) Junction box with mounted pressure switch and relay/timer.
- 1) 1 Ft. Length of 1/4 inch aluminum tubing.
- 1) 1/4 inch tubing connector
- 1) Flexible conduit connector
- 1) 4" MG1 Barometric Draft Control or 5" AF Barometric Draft Control

This device MUST be installed by a qualified agency in accordance with the manufacturers installation instructions.

The definition of a qualified agency is: *any individual, firm, corporation or company which either in person or through a representative is engaged in, and is responsible for, the installation and operation of gas appliances, who is experienced in such work, familiar with all the precautions required, and has complied with the requirements of the authority having jurisdiction.*

DO NOT DESTROY

THESE INSTRUCTIONS MUST REMAIN WITH EQUIPMENT



FIELD CONTROLS

The Venting Solutions Company™

2630 Airport Road · Kinston, NC 28504

Phone: 252-522-3031 · Fax: 252-522-0214

www.fieldcontrols.com

INSTALLATION INSTRUCTIONS

MOUNTING JUNCTION BOX

The junction box can be mounted at the venter or remotely mounted away from the venter. (See Figure 1 & Figure 2)

1. Remove one of the knockouts from the side of the junction box where the pressure switch is mounted. Install the flexible conduit connector onto the CK-43 junction box and secure with fastening nut. If remote mounting the CK-43 junction box, mount the flexible conduit connector onto a 2" x 4" installer supplied junction box.
2. Fasten the flexible conduit from the SWG Venter into the conduit connector. Mount the CK-43 junction box or installer supplied junction box onto the wall or floor joist without straining the flexible conduit. Fasten the CK-43 junction box through the four dimpled locations on the base of the box. (See Figure 3)

PRESSURE SWITCH SENSING TUBE INSTALLATION

1. Attach the 1/4 inch tubing connector to the pressure tube on the SWG Venter. (See Figure 3)
2. Connect the supplied 1/4" aluminum tubing to the tubing connector. Route the tubing to the CK-43 junction box and connect the tubing to the pressure switch. When routing the tubing, avoid kinking the tubing by bending the tubing too sharply.

For remote mounted CK-43 Junction Box, use a 1/4" OD copper, aluminum or plastic tubing and route the tubing to avoid contact with any heat source.

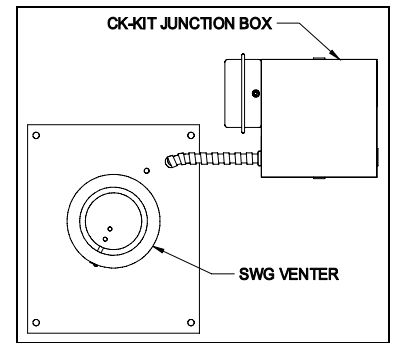

Figure 1

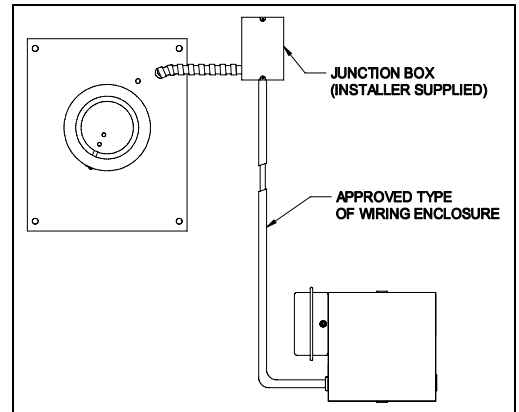

Figure 2

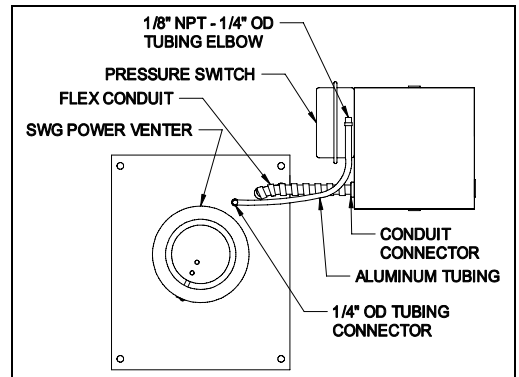

Figure 3

DRAFT CONTROL INSTALLATION

See Figure 4 for typical vent system layout.

CAUTION: *This draft control is shipped as a single acting draft control. If the draft control is not being used on a gas draft induced furnace, remove the gate stop on the draft control ring before installing.*

COLLAR INSTALLATION

This control is shipped with a collar patterned to fit a single wall round vent pipe. To attach this collar to the flue, see Figure 5 and follow the instructions below.

1. Bend outward the two ears at the front corners of the collar. Bend 90 degrees, 1/4 inch behind the single hole on the straps.
2. Insert clamping screw in ears on collar and bolt the remainder of the collar together.
3. Hold the collar against the side of the flue in the exact position it is to be installed (shown by dotted lines) and mark the outline of the collar on the flue.
4. Cut a hole in the flue about 1/2" inside of this outline.
5. Make a series of cuts about 1/2" apart from the edge of this hole to the outline marks.
6. Strap the collar to the flue pipe.
7. Bend the tabs formed by the series of cuts outward against the inside of the collar to make a tight joint.
8. Refer to Insertion of Draft Control Section.

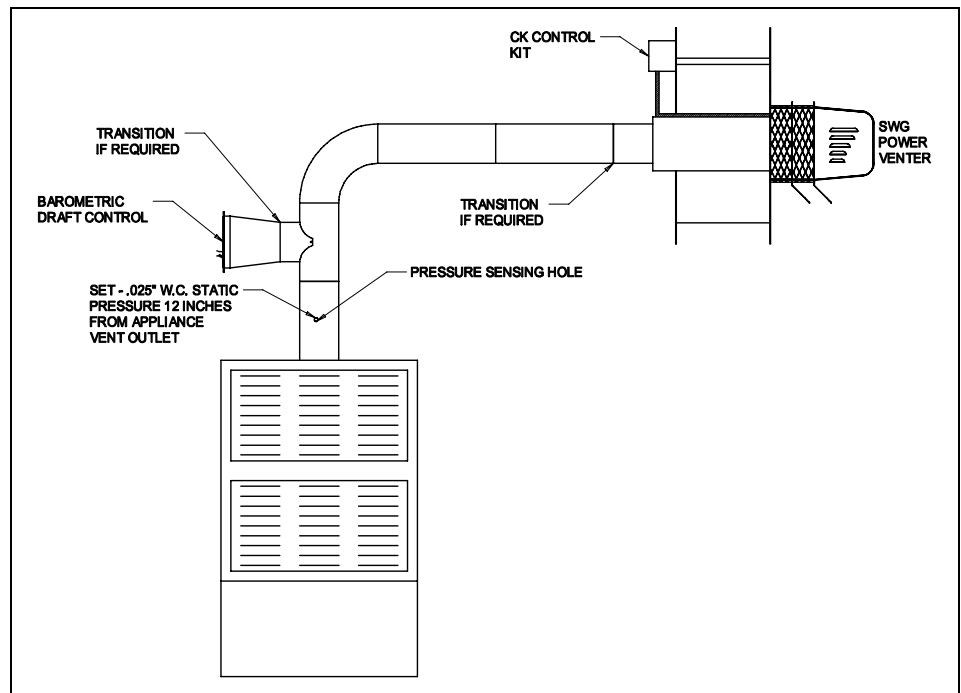

Figure 4

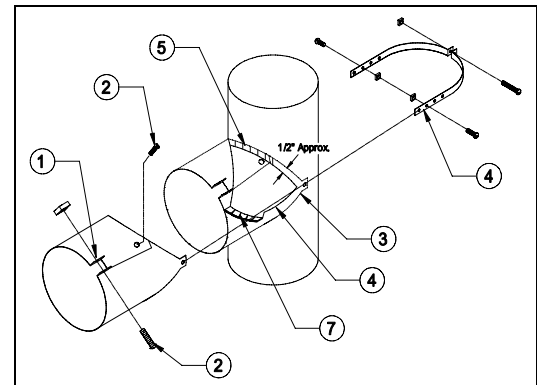

Figure 5

DRAFT CONTROL INSTALLATION IN TYPE B VENT PIPE

CAUTION: DO NOT use the supplied collar when mounting draft control to Type B Vent Pipe. Install by using a Type B Vent Pipe Tee.

1. Install a vent pipe reducer or increaser into the inner pipe and fasten using sheet metal screws. (See Figures 6 & 7)
2. The opening of the Type B Vent Tee, at the draft control mounting location, should be sealed with a high temperature sealant or equivalent.
3. Refer to Insertion of Draft Control Section.

INSERTION OF DRAFT CONTROL SECTION

Insert the draft control into the collar or tee. The front face of the control MUST be plumb and the bearing surfaces MUST be level whether the control is on a horizontal, vertical or sloping flue pipe. Use a spirit level and level accurately. (See Figures 6 & 7) Secure the control in the collar by tightening the clamping screws. If a tee is used or a collar is supplied locally, the control may be held in place by sheet metal screws.

ADJUSTMENTS

ADJUSTING THE DRAFT CONTROL WITH 4" MG1

The control MUST be adjusted to the desired draft setting by adding or removing the washer-type weights supported by the two chains on the side of the draft control. (See Figure 8) DO NOT move the weight attached directly to the gate, this is used only for balancing at the factory.

ADJUSTING THE DRAFT CONTROL WITH 5" AF

Vertical Flues Mounting - The control is shipped for installation in a vertical flue. The adjustment weight should be in the right hand slot when you face the control. See Figure 9.

Horizontal Flues Mounting - For horizontal flues, remove the weight from the right hand slot and attach it to the left hand slot as shown in Figure 9.

What Draft Setting to Use - When adjusting the control, two things are essential:

1. The burner must be operating for at least 10 minutes to obtain maximum chimney draft.
2. An analysis of the flue gases is necessary to determine the percentage of CO₂ and check for presence of CO. Refer to the appliance instructions and/or to the local gas company for the proper CO₂ readings and allowable CO levels. A rule of thumb for draft setting is between .01" to .03" of water column draft at the appliance outlet. (Check equipment requirement.)

Changes in the adjustment of the 4" MG1 control should be made by adding or removing the washer-like weights (supplied with the control) to or from the weight holder chain assembly. After the control is adjusted, it's action will be entirely automatic, the gate will open or close by itself to correct for changes in the draft that occur in the chimney.

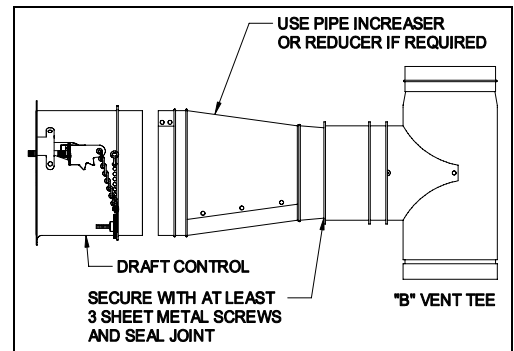

Figure 6

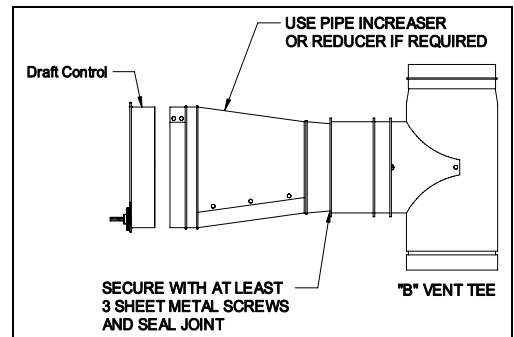

Figure 7

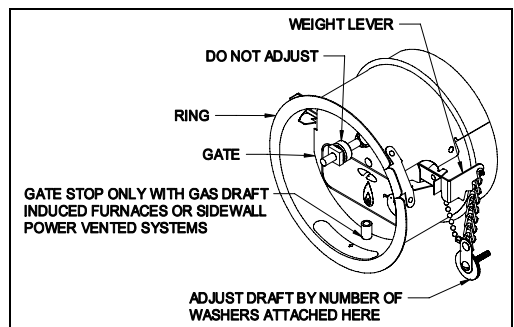

Figure 8

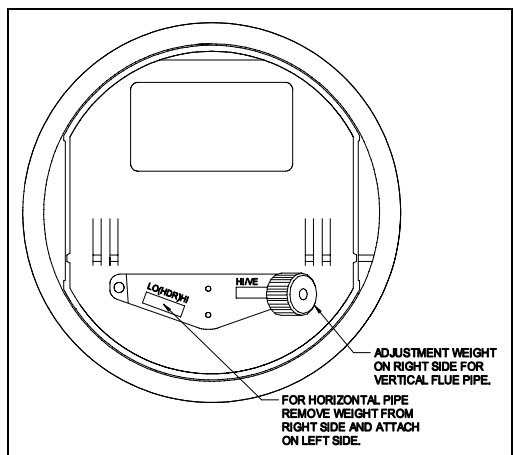

Figure 9

PROVING SWITCH ADJUSTMENTS

After proper air flow is established, the pressure switch adjustment is made by turning pressure switch adjustment screw clockwise (See Figure 10) until burner operation stops. Turn the adjustment screw counter clockwise until burner ignites. Turn the adjustment screw an additional 1/4 to 3/4 turn counterclockwise to ensure adequate switch adjustment.



WARNING: Failure to properly adjust the pressure switch as specified above could lead to improper operation of the pressure switch which will result in a hazardous condition and bodily harm!

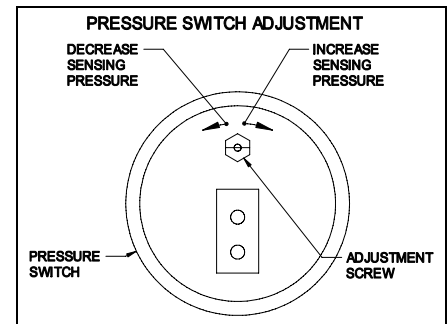

Figure 10

THERMOSTAT HEAT ANTICIPATOR ADJUSTMENT

After venting kit installation and checkout, check the amperage current draw through the thermostat circuit and adjust the thermostat anticipator accordingly.

POST PURGE TIMER ADJUSTMENT

To adjust the post purge time, refer to Figures 11 & 12.

For timer that looks like Figure 11: Rotate the timer adjustment on the timer clockwise to increase the operation time. To decrease the operation time, rotate the timer adjustment counterclockwise.

For timer that looks like Figure 12: Rotate the timer adjustment on the timer counterclockwise to increase the operation time. To decrease the operation time, rotate the timer adjustment clockwise.

*Typical post purge time should be between 3 to 5 min.

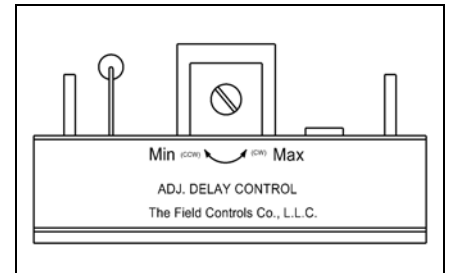

Figure 11

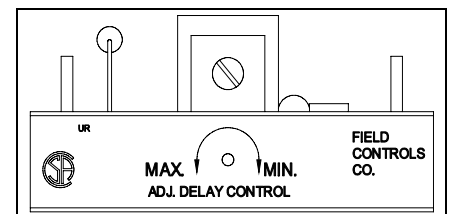

Figure 12

WIRING

CAUTION: Disconnect electrical power when wiring power venter.

NOTE: If using this control kit with an electronic thermostat you need an RJR-5 isolation relay. Wire the venter motor and controls in accordance with the National Electrical Code, manufacturer's recommendations and/or applicable local codes. UNITS MUST BE GROUNDED. Check ground circuit to make certain that the unit has been properly grounded. The wiring should be protected by an over current circuit device rated at 15 amperes. CAUTION must be taken to insure that the wiring does not come into contact with any heat source. All line voltage and safety control circuits, between the venter and the appliance, MUST be wired in accordance with the National Electrical Code for class one wiring or equivalent methods. Route the venter motor and control wiring with an appropriate wiring method. Refer to the Wiring Diagram A.

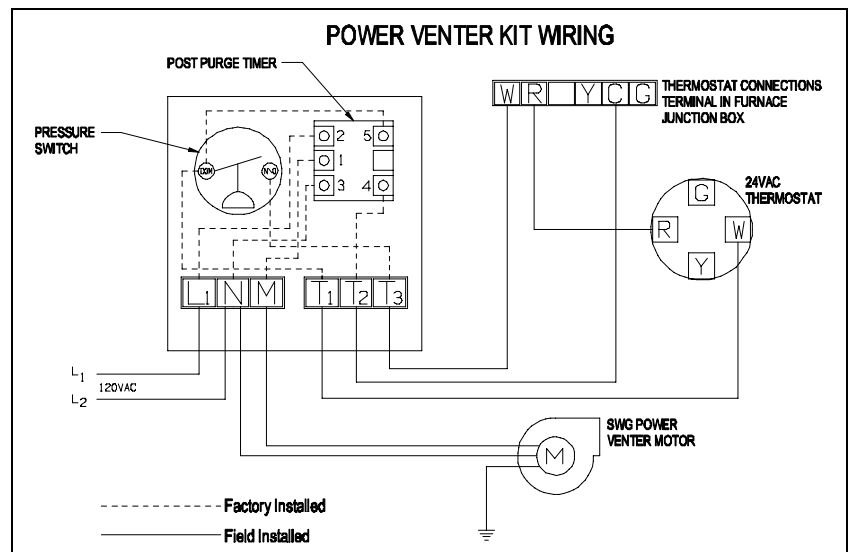

Diagram A

SYSTEM CONTROL CHECK OUT PROCEDURES

1. Adjust the thermostat to call for heat and observe the power venting system for proper operation sequence (Repeat if necessary).
 - a. Thermostat calls for heat.
 - b. Relay is energized and venter motor starts.
 - c. Pressure switch closes and burner starts.
 - d. Thermostat is satisfied, the burner stops.
 - e. This starts the post purge cycle.
2. While system is operating disconnect power to the venter motor. This should open the pressure switch contacts and stop burner operation.

TROUBLE SHOOTING HINTS

1. Main burner does not fire when thermostat calls for heat with venter operating.
 - a. Check pressure switch adjustment.
 - b. Check wiring connections between pressure switch and burner. c. Check pressure switch for continuity across terminals, during venter operation.
2. Venter does not activate when thermostat calls for heat.
 - a. Check wiring.
 - b. Check relay for proper operation.
3. Flue gas odor.
 - a. Check system draft.
 - b. Check for negative pressure in building.
 - c. Check post purge time.

MAINTENANCE

1. **Motor:** Inspect motor once a year, the motor should rotate freely.
2. **Wheel:** Inspect venter wheel annually to clear any soot, ash or coating which inhibits either rotation or air flow. Remove all foreign material before operating.
3. **Vent System:** Inspect all vent pipe connections annually for looseness and for evidence of flue gas leakage. Seal or tighten pipe connections if necessary.

INSTALLATION INFORMATION

MODEL NO.: _____ CK-43 Control Kit _____

INSTALLER'S NAME: _____

INSTALLER'S COMPANY: _____

INSTALLER'S PHONE NO.: _____

DATE OF INSTALLATION: _____



FIELD CONTROLS

The Venting Solutions Company™